

## Reading 11

Ron Bertrand VK2DQ  
<http://www.res.net.au>

### CAPACITANCE

In this reading we are going to talk about capacitance. I have to make a distinction here between capacitor and capacitance. A capacitor is a device, whereas capacitance is an electrical property. First we will discuss the capacitor and then the property of capacitance. We will avoid mathematics where possible.

#### Construction

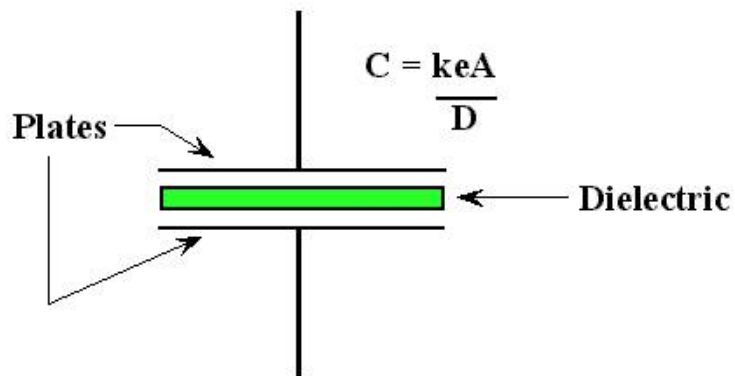

Figure 1(a).

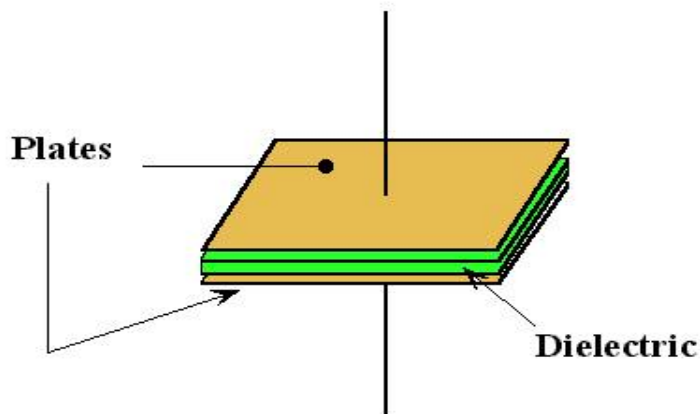

Figure 1(b).

As you can see a capacitor is a two terminal device. There is always an insulator between the plates of a capacitor. This should suggest to you that current never flows **through** a capacitor.

Some basic schematic symbols for capacitors:

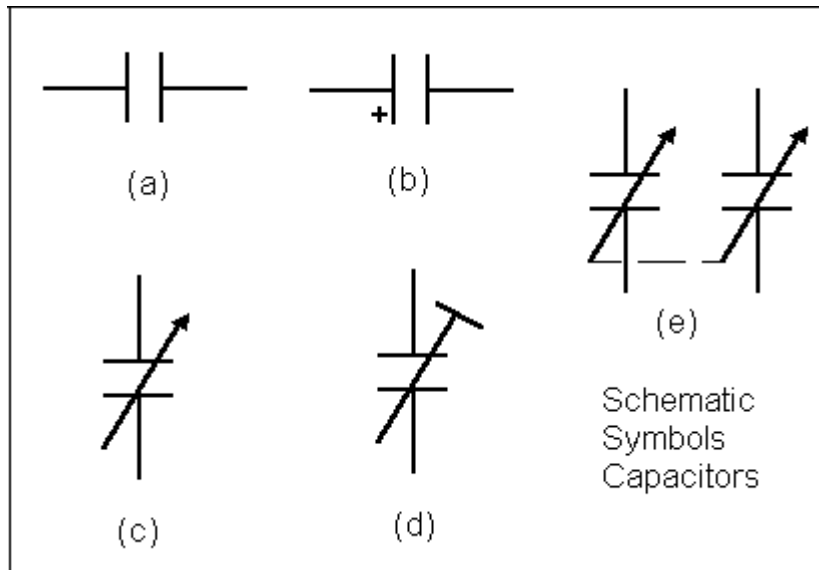

Figure 2.

Figure 2(b) shows a polarised (electrolytic) capacitor. This type of capacitor has its dielectric formed electrically, and must only be used in DC circuits. Figures 2(c), (d), and (e) are all variable capacitors. Figure 2(d) is often called a trimmer capacitor, as it is adjusted with a small screwdriver and is often used to “trim” the capacitance in a circuit. Sometimes two or more variable capacitors are used on the one shaft, so that when the shaft is turned, all of the capacitors are made to vary. This is shown in 2(e). With such a capacitor, all the capacitors on the common shaft do not have to be the same.

Some capacitor packages:

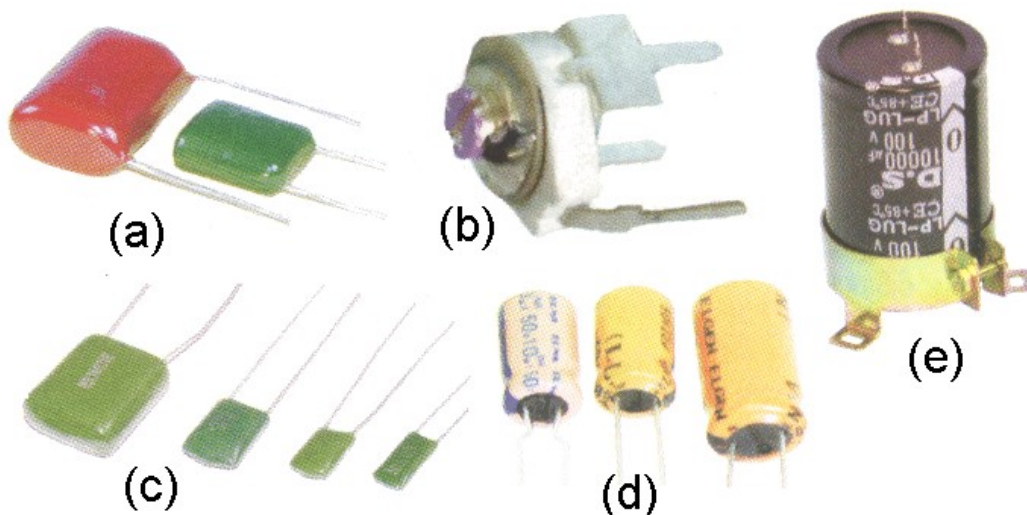

Figure 3.

Figures 3(a) and (c) – polyester dielectric capacitors; 3(b) – Trimmer capacitor; 3(d) and (e) electrolytic (polarised) capacitors. Photos not to scale.

The interesting stuff starts to happen when we connect an EMF to the plates of a capacitor. Have a look at the test circuit of figure 4.

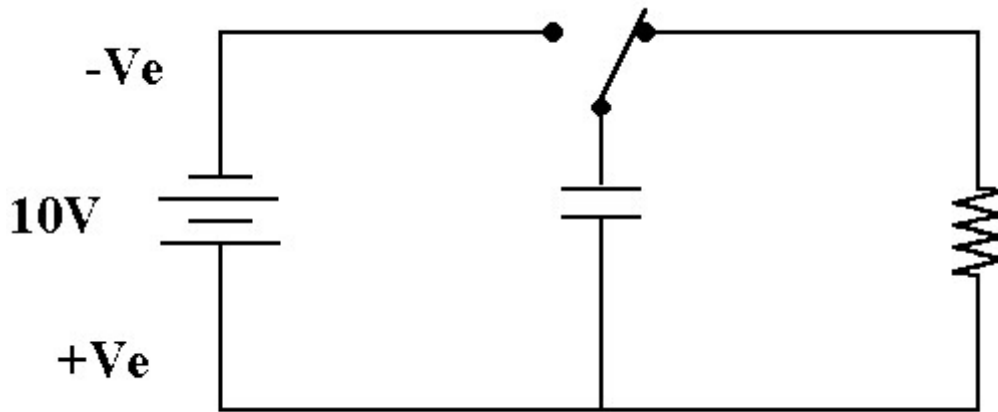
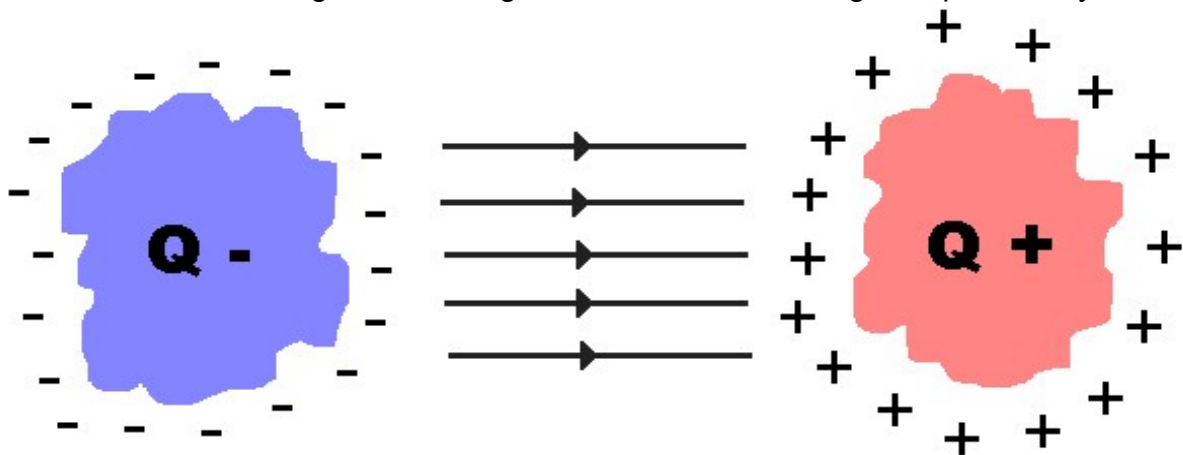

Figure 4.

The capacitor can be switched, so that it will be connected to the 10 volt battery when the switch is thrown to the left, or when the switch is thrown to the right it will be connected to the resistor. The capacitor can be connected by the switch to the battery or the resistor, but not both at the same time. The symbols  $-Ve$  and  $+Ve$  on the battery are shorthand for negative and positive charge.

The negative terminal of the battery has an excess of electrons on it, created by the chemical action in the battery. The positive terminal has a deficiency of electrons. Now recall that **unlike charges attract**. If there were any way for the electrons to get from the negative terminal of the battery to the positive, they would. I just want you to imagine a battery by itself with two terminals, for a moment. There is an electrostatic field between the two terminals of any battery created by the unlike charges on each terminal. In other words there is a very slight tugging from the positive terminal, and a very slight pushing from the negative terminal in a vain attempt to move electrons from the negative to the positive terminal. No current flows between the unconnected terminals of a battery because the electrostatic fields are very small due to the spacing of the battery terminals and the very high air resistance between them.

If you find this hard to imagine look at figure 5 below of two charges separated by air.



**ELECTRIC FIELD - ELECTRONS 'WANT'  
TO MOVE TO THE POSITIVE LUMP**

Figure 5.

Here we have two lumped charges  $Q_1$  and  $Q_2$ . There is an electrostatic field between them. This field is trying to pull electrons from the negative charge over to the positive charge. There is an electrical strain here. No current flows because the two charges are too far apart. Let's say they are 100mm to start with. Now move the two lumped charges so that they are only 50mm apart. The electrostatic field will now be stronger. The strain will be stronger. Still no current flows. Let's push the issue. Move the two lumped charges so that they are only 5mm apart. Now (depending on the charges) the electrostatic field will be immense. The tugging of electrons from the negative charge will be enormous. Still no current flows, as the air insulation between the charges is too great.

The electrons on the negative lumped charge want to traverse the gap to the positive charge. Do you think the electrons would be evenly distributed on the negative lump? On the side of the negative lump closest to the positive lump (the inside) the electrons will be crowding up trying to jump the gap.

Can you figure out what will happen if we continue to move them closer, say, to 1 mm? Well I think you will agree that a point will be reached where the electrostatic field is so strong that electrons will jump off the negative lump and flow through the air to the positive lump. There will be an arcing of electric current. This is what happens in a lightning storm.

Back to our capacitor connected at the moment to the resistor. The switch is thrown to the right. The plates of the capacitor have a very **large area**. The dielectric between the plates is extremely thin but still a very good insulator. When we throw the switch to the left as in figure 6, we are in fact extending the charges on the battery terminals to the plates of the capacitor, and there will be a strong electrostatic field across the plates of the capacitor and through the dielectric.

Electrons are going to **move** from the negative terminal of the battery and bunch up on the top plate of the capacitor. Similarly, electrons are going to **move** from the bottom plate and travel to the positive terminal of the battery. No electrons will be able to flow though the dielectric. Its insulating properties are too good. So, if you like, there is going to be a **redistribution of charge**. This movement of charge will continue until the electrons flowing into and out of the capacitor create a potential difference on the plates of the capacitor equal to the battery voltage, namely 10 volts. The capacitor is now said to be **charged**.

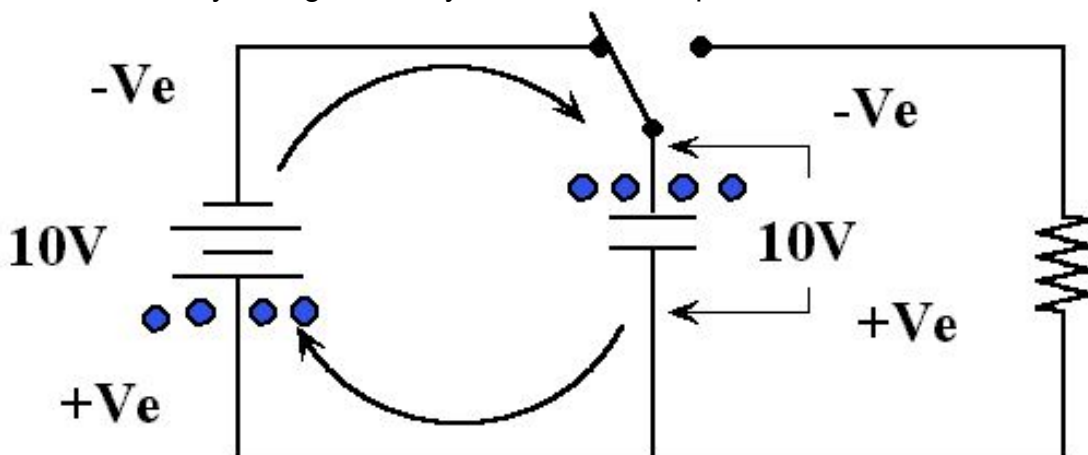

Electrons flow into and out of the capacitor  
 No electrons flow through the capacitor

Figure 6 – Capacitor charging.

This charging of the capacitor does not happen instantaneously - it takes a little time. Suppose now we move the switch so the capacitor is disconnected from the circuit, as shown in figure 7.

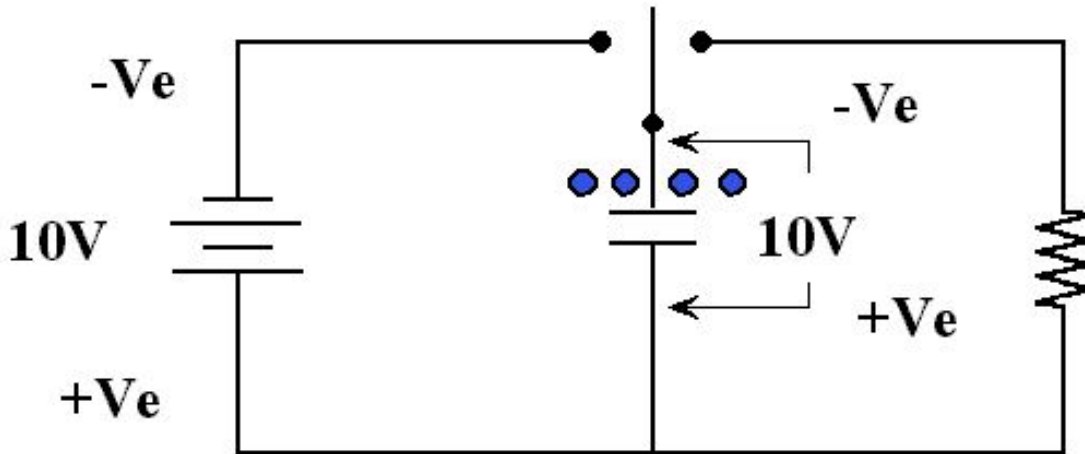

Figure 7 – Capacitor disconnected from circuit.

The capacitor is now left charged, even though it has been disconnected from the battery. The capacitor has 10 volts across it. Older capacitors would not hold this charge for very long as a current would slowly leak through the dielectric and the capacitor would eventually self-discharge. Some modern capacitors can hold their charge for days or longer.

The capacitor has stored energy in it in the form of a charge on the plates. If we connect a circuit to the capacitor it will discharge, as shown in figure 8.

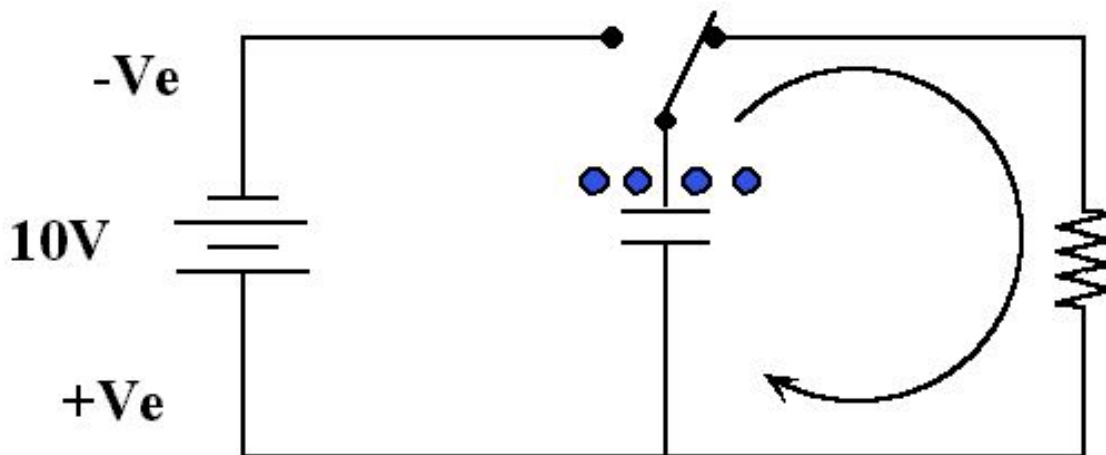

Figure 8 – Capacitor discharging.

Electrons will now flow from the top plate of the capacitor through the resistance, until the capacitor becomes discharged. If the resistor was a small light bulb it would flash brightly at first and then slowly dim as the capacitor discharges.

At no time did current flow through the dielectric of the capacitor

Suppose the resistor was a lamp. Also, suppose we continue to rapidly move the switch back and forth between the left and right position. The lamp would perhaps flicker a bit, but be continuously lit.

So you should now see that a capacitor can be used to store charge and we can use that charge to do something.

### Where is the energy stored?

Though we have said that energy has been stored by the charge on the plates, it is more correct to say that the energy is stored in the electric field. It is the charge on the plates that forms the electric field between the plates. When current flows into a capacitor, charging it, the electric field becomes stronger (stores more energy). When the current flows out of the capacitor, the voltage across the plates decreases and hence the strength of the electric field decreases (energy moves out of the electric field).

## UNIT OF CAPACITANCE

The unit of capacitance is called the **Farad**. The farad is the measure of a capacitor's ability to store a charge. If one volt is applied to the plates of a capacitor and this causes a charge of 1 Coulomb to be stored on the plates, the capacitance is 1 Farad.

In practice 1 farad is an enormous capacitance. More practical sub-units of the farad are used. Microfarad and picofarad are the most common sub-units.

$$1 \text{ microfarad} = 1 \times 10^{-6} \text{ Farads}$$

$$1 \text{ nanofarad} = 1 \times 10^{-9} \text{ Farads}$$

$$1 \text{ picofarads} = 1 \times 10^{-12} \text{ Farads}$$

## PERMITTIVITY OR DIELECTRIC CONSTANT

The insulating material between the plates (dielectric) determines the concentration of electric line of force. Just like different materials will concentrate magnetic lines of force to a greater or lesser extent, materials also vary in their ability to concentrate electric lines of force.

If the dielectric was air, then a certain number of lines of force will be set up. Some papers have a dielectric constant twice that of air, which would cause twice as many lines of force to be set up and the capacitance would be double. The higher the dielectric constant the greater the capacitance for a given plate area.

Suppose an air dielectric capacitor (dielectric constant close enough to 1) of 8 microfarads had its air dielectric replaced with mica, without changing the distance between the plates. The capacitance would increase in direct proportion to the dielectric constant. In other words, the capacitance would increase from 8 microfarads to 5-7 times that value, or 40 to 56 microfarads.

## DIELECTRIC CONSTANTS

Material	Dielectric Constant
Vacuum	1
Air	1.0006
Rubber	2-3
Paper	2-3
Ceramics	3-7
Glass	4-7
Quartz	4
Mica	5-7
Water	80
Barium titanate	7,500

Table 1 – Dielectric constant values.

## FACTORS DETERMINING CAPACITANCE

A formula to determine the capacitance of a two-plate capacitor is:

$$C = \frac{KeA}{d} \times 8.85 \times 10^{-12} \text{ F}$$

Where:

A = is the area in square metres of either plate.

Ke = the dielectric constant.

d = distance between the plates in metres.

The constant  $8.85 \times 10^{-12}$  is the absolute permittivity of free space.

**Example.** Calculate C for two plates, each with an area of 2 square metres, separated by 1 centimetre ( $1 \times 10^{-2}$  metres), with a dielectric of air.

We will take the dielectric constant of air as 1. Even though it is more accurately 1.0006, 1 is close enough, so that:

$$\begin{aligned} C &= \frac{1 \times 2 \times 8.85 \times 10^{-12}}{1 \times 10^{-2}} \\ &= 200 \times 8.85 \times 10^{-12} \\ &= 1770 \times 10^{-12} \\ &= 1770 \text{ pF (picofarads)} \end{aligned}$$

For examination purposes you do not have to use this equation. However, you most definitely do need to know what the equation says about the factors determining capacitance.

$$C = \frac{KeA}{d} \times 8.85 \times 10^{-12} \text{ F}$$

Capacitance is directly proportional to the dielectric constant (Ke).

Capacitance is directly proportional to the area of one of the plates (A).

Capacitance is inversely proportional to the distance between the plates (d).

## CAPACITORS IN SERIES AND PARALLEL

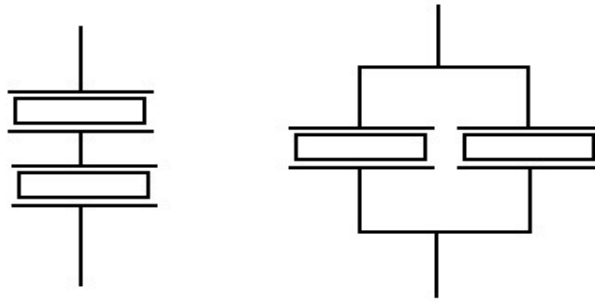

Figure 9 - (a) Series and (b) Parallel capacitors.

In figure 9 above all the capacitors are the same. Let's say they are 10 microfarads. Think about what happens when you connect two identical capacitors in series. Think about it in terms of the factors that we just discussed, that affect capacitance. Can you visualise by looking at the series capacitors (on the left of figure 9) that we have actually **doubled** the thickness of the dielectric? Doubling the thickness of the dielectric is exactly the same thing as doubling the **distance between the plates**.

If the distance between the plates is doubled, and capacitance is inversely proportional to the distance between the plates, then the capacitance must be half of a single capacitor on its own. The total capacitance of two 10 microfarad capacitors in series must then be 5 $\mu$ F.

The equation for any number of capacitors of any value in series is:

$$1/C_t = 1/C_1 + 1/C_2 + 1/C_3 + \dots \text{ etc}$$

OR

$$C_t = \frac{1}{1/C_1 + 1/C_2 + 1/C_3 + \dots \text{ etc}}$$

The easiest way to use this equation on a calculator is:

1. Find the reciprocal of each capacitance.
2. Add all of the reciprocals together (sum them).
3. Find the reciprocal of this sum.

In other words, the reciprocal of the sum of the reciprocals.

### [Worked example](#)

Take three capacitors of 7, 8 and 12 microfarads in series.

Find the reciprocal of 7:  $1/7 = 0.143$  (rounded to 3 decimal places)

The reciprocal of 8 :  $1/8 = 0.125$

The reciprocal of 12:  $1/12 = 0.083$

The sum of the above is: 0.351

Find the reciprocal of this sum:  $1/0.351 = 2.85$  microfarads.

Three capacitors of 7, 8 and 12 microfarads in series has a total capacitance of 2.85  $\mu\text{F}$ . Notice how the total capacitance is **always** less than the lowest value capacitor.

Note: If just two capacitors are in series then you can use the simplified product over sum formula.

For two capacitors (only) in series:

$$C_t = (C_1 \times C_2) / (C_1 + C_2)$$

When the same two capacitors are connected in parallel, the distance between the plates and all other factors remain the same, except we have **doubled** the effective area of the plates. So the capacitance has doubled.

The equation for any number of capacitors of any value in parallel is:

$$C_t = C_1 + C_2 + C_3 + \dots \text{ etc}$$

These equations are opposite to that of resistances in parallel and series, so be careful not to confuse the two. The shortcuts we took with resistors in parallel work the same for capacitors in series. For example, if we have just two capacitors of any value in series we can use the product over sum method to find the total capacitance.

## VOLTAGE ACROSS SERIES CAPACITORS

If two equal capacitors were connected in series across a 100 volt DC supply and we were to measure the voltage across each capacitor we would get 50 volts across each. Since the capacitors are equal we get an equal voltage drop.

For unequal capacitances in series the voltage across each C is inversely proportional to its capacitance. In other words the smallest capacitance would have the largest voltage drop. The largest capacitance would have the smallest voltage drop.

The amount of charge on a capacitor is given by:

$$Q = CE$$

If a 10  $\mu\text{F}$  capacitor was charged to 10 volts, then the charge in coulombs on the capacitors would be:

$$10\mu\text{F} \times 10 \text{ volts} = (10 \times 10^{-6})\text{F} \times (10)\text{V} = 10^{-4} \text{ Coulombs.}$$

The equation can be transposed for voltage across a capacitor and we get:

$$E = Q/C$$

In a series circuit, each capacitor regardless of its capacitance will have the same charge.  $Q$  is the same for all capacitances in series. For a smaller capacitance to have the same charge in a series circuit it must have a higher  $E$ .

We could do mathematical examples, however, you do not need this in practice or for examination purposes. You do need to understand and be able to visualise the voltage drops across capacitances in a series circuit.

Example. Two capacitances of 1 $\mu$ F and 2 $\mu$ F are connected in series across a 900 volt DC supply. What is the voltage drop across each capacitor?

Now, the voltage drops have to be unequal because each capacitor will have the same charge ( $Q$ ).

$$E = Q/C$$

$E$  is inversely proportional to  $C$ . Therefore the smallest  $C$  (1 $\mu$ F) must have the greatest voltage drop. But how much greater? Since the 1 $\mu$ F capacitor is half the value of the 2 $\mu$ F capacitor, it must have twice the voltage to achieve the same charge. The 1 $\mu$ F capacitor must then have 600 volts across it, leaving 300 volts on the 2  $\mu$ F capacitor.

## VOLTAGE RATING OF CAPACITORS

All capacitors are given a maximum voltage rating. This is necessary as the dielectric of capacitors can breakdown and conduct, causing the capacitor to fail and in most cases be destroyed. Some capacitors, if placed across a voltage which is too high, will create gas within them and explode fairly violently.

We will discuss types of capacitors in the next reading.

End of Reading 12.

Last revision: January 2016

Copyright © 1999-Present. Ron Bertrand

E-mail: [admin@res.net.au](mailto:admin@res.net.au)

<http://www.res.net.au>

Free for non-commercial use with permission